

■ Pipe clamp HDC 30x2,5 60 - 65 mm M10 unlined

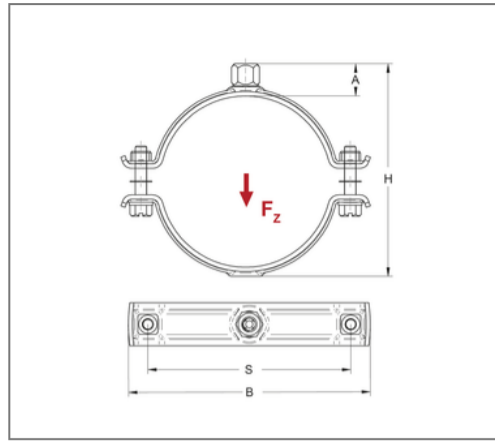

Commercial details

Part no.	47300060
EAN/GTIN	4250928458254
Packing unit	25 pcs
Quantity unit	pcs
Weight	0,217 kg/pc
Product group	12-034
Price unit	100

QR code



Certification



Specification

Brand	Jiangmen Eurofix
Application	Pipe clamp with connection thread according to area sprinkler guidelines for Sprinkler systems.
Specification	two-part
Connection	M10
Closure	Screw coupling

Technical data

Material	Steel
Surface	galvanized
Corrosion category	C2 very high
Surrounding area	Indoor area
Sound insulation lining	unlined

Product details

Center distance S	87 mm
Connection height A	18 mm
Width B	108 mm
Height H	87 mm
Material dimension	30x2,5 mm
Load F_z	2,5 kN
min. outside pipe diameter	60 mm
max. outer pipe diameter	65 mm
Outside pipe diameter inch	val.RohraußendurchmesserZoll.2 inch
Closure screw	M8
Tightening torque	3 Nm