

## ■ Pipe clamp HDC 30x2,5 20 - 24 mm M10 unlined

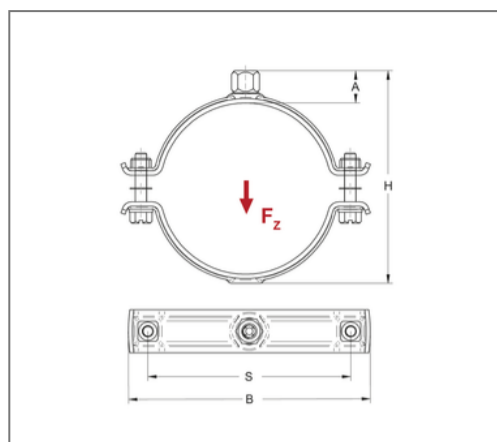

### Commercial details

Part no.	47300022
EAN/GTIN	4250928458209
Packing unit	50 pcs
Quantity unit	pcs
Weight	0,141 kg/pc
Product group	12-034
Price unit	100

### QR code



### Certification



### Specification

Brand	Jiangmen Eurofix
Application	Pipe clamp with connection thread according to area sprinkler guidelines for Sprinkler systems.
Specification	two-part
Connection	M10

### Technical data

Material	Steel
Surface	galvanized
Sound insulation lining	unlined

### Product details

Center distance S	44 mm
Connection height A	17 mm
Width B	66 mm
Höhe H	44 mm
Material dimension	30x2,5 mm
load $F_z$	2,5 kN
min. outside pipe diameter	20 mm
max. outer pipe diameter	24 mm
Outside pipe diameter inch	1/2 inch
Closure screw	M8