

■ Nail anchor N-M 6-30 M8/10 With sleeve SW 13

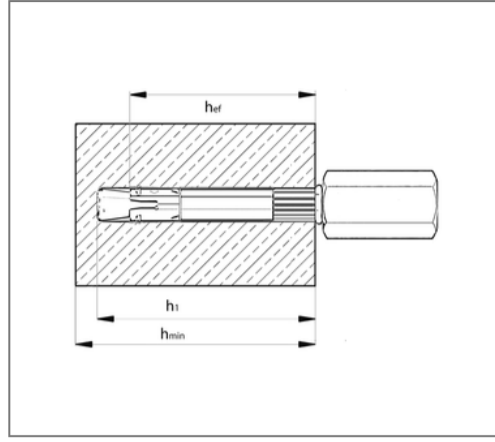

Commercial details

Part no.	221860315101
EAN/GTIN	4043315104915
Packing unit	100 pcs
Quantity unit	pcs
Weight	0,0285 kg/pc
Product group	07-221
Price unit	100

QR code



Certification



Specification

Application area	For multiple fixings in cracked concrete C12/15 - C50/60, e.g. ceiling suspensions, piping, cladding, cable trays and rail fastening.
Specification	With sleeve

Product details

Female thread	M8/M10
Wrench size	13
Drill diameter	6 mm
Drilling hole depth	40 mm
Length dowel	63 mm
Depth of anchoring	30 mm

Technical data

Material	Steel
Surface	galvanized
Corrosion category	C2 very high
Surrounding area	Indoor area