

■ Nail anchor N-M 6-25 M8/10 With sleeve SW 13

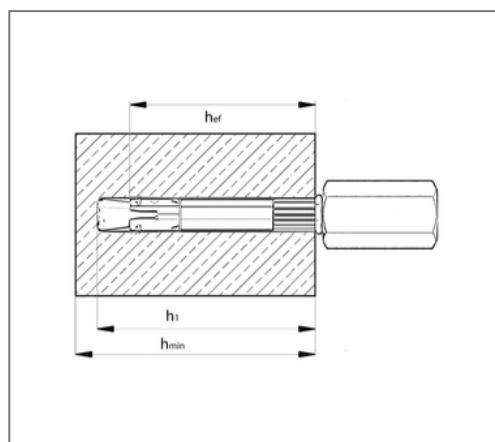

Commercial details

Part no.	221860310101
EAN/GTIN	4043315104908
Packing unit	100 pcs
Quantity unit	pcs
Weight	0,0275 kg/pc
Product group	07-221
Price unit	100

QR code



Certification



Specification

Application	For multiple fixings in cracked concrete C12/15 - area C50/60, e.g. ceiling suspensions, piping, cladding, cable trays and rail fastening.
Specification	With sleeve

Product details

Female thread	M8/M10
Wrench size	13
Drill diameter	6 mm
Drilling hole depth	35 mm
Length dowel	58 mm
Depth of anchoring	25 mm

Technical data

Material	Steel
Surface	galvanized
Corrosion category	C2 very high
Surrounding area	Indoor area