

■ Double holder VSG with threaded pin Center distance L 46 - 154 mm

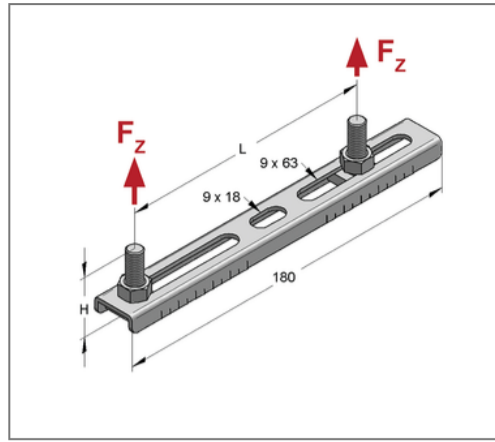
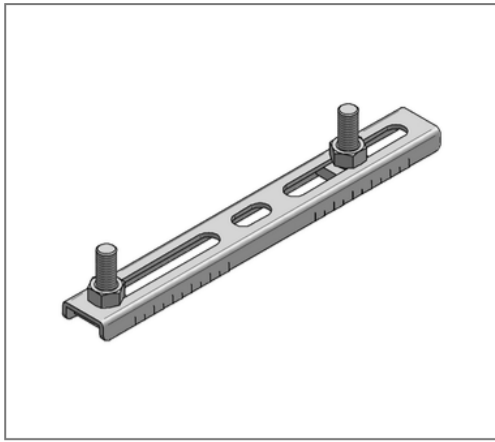

Commercial details

Part no.	0590118
EAN/GTIN	4250928415080
Packing unit	50 pcs
Quantity unit	pcs
Weight	0,122 kg/pc
Product group	05-076
Price unit	100

QR code



Specification

Application area	Double holder with continuously adjustable threaded bolts.
------------------	--

Technical data

Material	Steel
Material type	S235
Surface	galvanized
Corrosion category	C2 very high
Surrounding area	Indoor area

Product details

Center distance L	46 - 154 mm
Height H	20 mm
Length	180 mm
Threaded pin type	M8x20
Load F_z	0,35 kN