

## ■ Double holder with female thread Center distance L 65 mm Connection M8

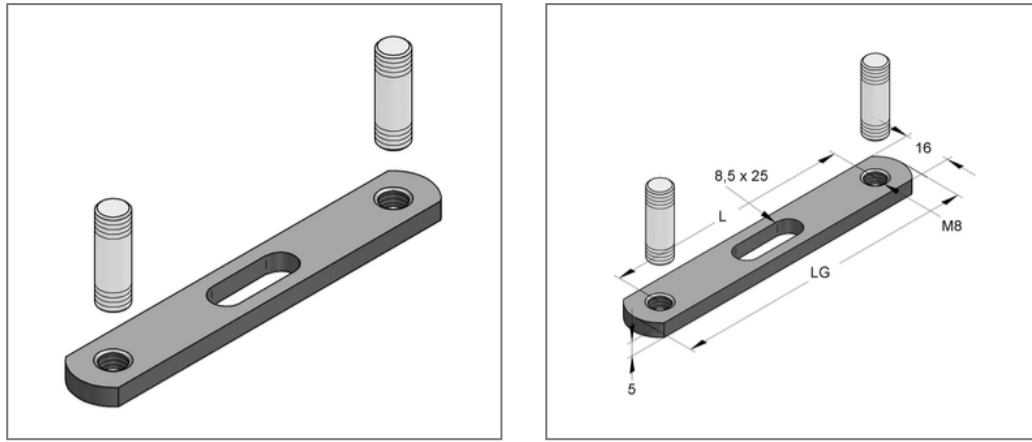

### Commercial details

Part no.	0763071
EAN/GTIN	4250928417367
Packing unit	100 pcs
Quantity unit	pcs
Weight	0,0410 kg/pc
Product group	05-076
Price unit	100

### QR code



### Specification

Application Holder with female thread for fastening two parallel pipelines in combination with pipe clamps.

### Technical data

Material	Steel
Material type	S235
Surface	galvanized
Corrosion category	C2 very high
Surrounding area	Indoor area

### Product details

Center distance L	65 mm
Width	16 mm
Height H	5 mm
Length LG	87 mm
Load $F_z$	0,2 kN